



International Standard Works Area

WORKS AREA POLICY AND INFORMATION BOOKLET



FREMANTLE SAILING CLUB

CONTENTS

Works Area Policy and Information Sheet Introduction	3
Lifts	4
Waste Disposal	6
Safety	8
Safe Work Practices	10
Appendix : Map of FSC Works Area	12
Appendix: Emergency Procedure Map	13

CONTACT FSC WORKS AREA

E-mail: maintenance@fsc.com.au

Glen Moore: 0421 637 238

Office Number: 9435 8853

Bookings can be made via our Website:

fsc.com.au/boatyard-booking-form

PA: PO Box 860, Fremantle, WA 6959

Address: 151 Marine Terrace, Fremantle WA, 6160160



WORKS AREA POLICY & INFORMATION SHEET

PLEASE READ CAREFULLY AND COMPLY WITH THIS POLICY

INTRODUCTION

This information sheet is provided to assist you during your period of work in the Fremantle Sailing Club Works Area. If you have any queries, please speak to any of the WorkTeam and they will do their best to assist you.

Vessel Owners' Responsibilities

Vessel owners are responsible for the conduct of all tradesmen working on their vessels. It is the responsibility of vessel owners to arrange appropriate access and to provide guidance to their tradesmen on the activities permitted in various areas of the Club. Please ensure that tradesmen have access keys, parking permits and observe Club Rules and etiquette. A list of all Approved Contractors at Fremantle Sailing Club is available from our website www.fsc.com.au/registered-contractors-trades. Works area policy + FSC Safework Practices and Club Rules acknowledged.

Tradesmen's Responsibilities

As a private members' Club, tradesmen only have authority to be on the Club premises at the invitation of a member to work on their vessel or if contracted by Fremantle Sailing Club for official Club tasks. All contractors must complete the necessary forms prior to commencement of work, this includes signing the Club Rules, submitting insurance documentation for Workers Comprehensive Insurance and Marine Combined Liability or Ship Repairers Combined liability. All contractors must undertake the Fremantle Sailing Club Works Area Induction prior to entering the Works Area (<https://fsc.com.au/tradesman-form/>). This induction can be done prior to arriving at Fremantle Sailing Club, contact the club for further details.

Vessel Maintenance In Pens

Any maintenance activity on vessels that involves sanding, grinding, metal cutting, welding or spray painting, or work that is likely to foul an adjacent vessel, is not to be conducted in pens. The vessel is to be removed to the Service Jetty for such work. Booking arrangements are made through the boatyard booking form <https://fsc.com.au/boatyard-booking-form/>.

It is expected that while working on the Club grounds that both Club Members and their Tradesmen will take full care and responsibility to ensure that their work practices do not cause damage to the Club, its property, the property of any other person or the environment.

When driving on Club grounds please drive carefully and in accordance with posted speed limits.

CLUB ACCESS AND PARKING

Works Area

The Works Office and boatlift operating hours are Monday to Friday 0730-1600 hrs. Other times can be organised by special arrangement.

Contractors access 0600 - 1800 Monday - Friday.

Parking

Members and Tradesmen are advised that the hardstand area is a designated work environment. Parking of vehicles in the Works Area is at your own risk. The Club will not be held responsible for any damage whatsoever that may result to your vehicle whilst on the Club grounds. A maximum of two vehicles including members vehicle will be permitted to be parked in the service area for each boat being loaded, serviced, or moored in the land-backed pens and we ask everyone to walk to vessels when possible.

When parking your vehicle in the Works Area, please be aware that the Boatlift Cranes and the FRANNA crane need access to any bay at any time, so please park behind the white lines and be available to move the vehicle when requested. A locked car with no driver around can delay the operations of the yard for some time. If you park in the works area please leave your car unlocked and your car keys in a visible position so that staff are able to move your vehicle if required. Alternatively, you can leave your car locked in the carpark.

LIFTS

Lift Times

The normal liftout times are 8am, 9:30am, 11am, 1pm, 2pm and 3pm, usually with larger vessels in the mornings. During the busy season, the yard waiting list can be up to three weeks, so book early. Hull inspections are also by appointment. Please remember to ask for special requests when booking. These include but are not limited to 3 slings, 4 slings, short slings, rope deflectors, a transducer in an odd position etc.

Morning lifts are for vessels 45' and over, afternoon lifts 45' and under on lifting out vessels.

The Liftout

Please have four mooring lines at least 8-10 metres in length ready to throw to the staff when instructed. Make sure they are cleated to the vessel. The vessel lift operator will signal by waving for you to enter the lifter bay. Proceed slowly and stop adjacent to the catwalks. Throw the stern lines first and the staff will walk the vessel into the bay. This prevents the slings twisting underwater from the propeller wash.

Sling Positions

The Club Staff can take no responsibility for the position of the slings during the lift. The vessel lift operator will not lift until the vessel skipper, owner or the owner's representative has given the go-ahead. Please ask the staff for the sling marking stickers available at no cost from the Works Office or the Harbourmaster. Affix these to the sides of your vessel immediately below the gunwale to indicate the correct lifting points.

Sling Positions

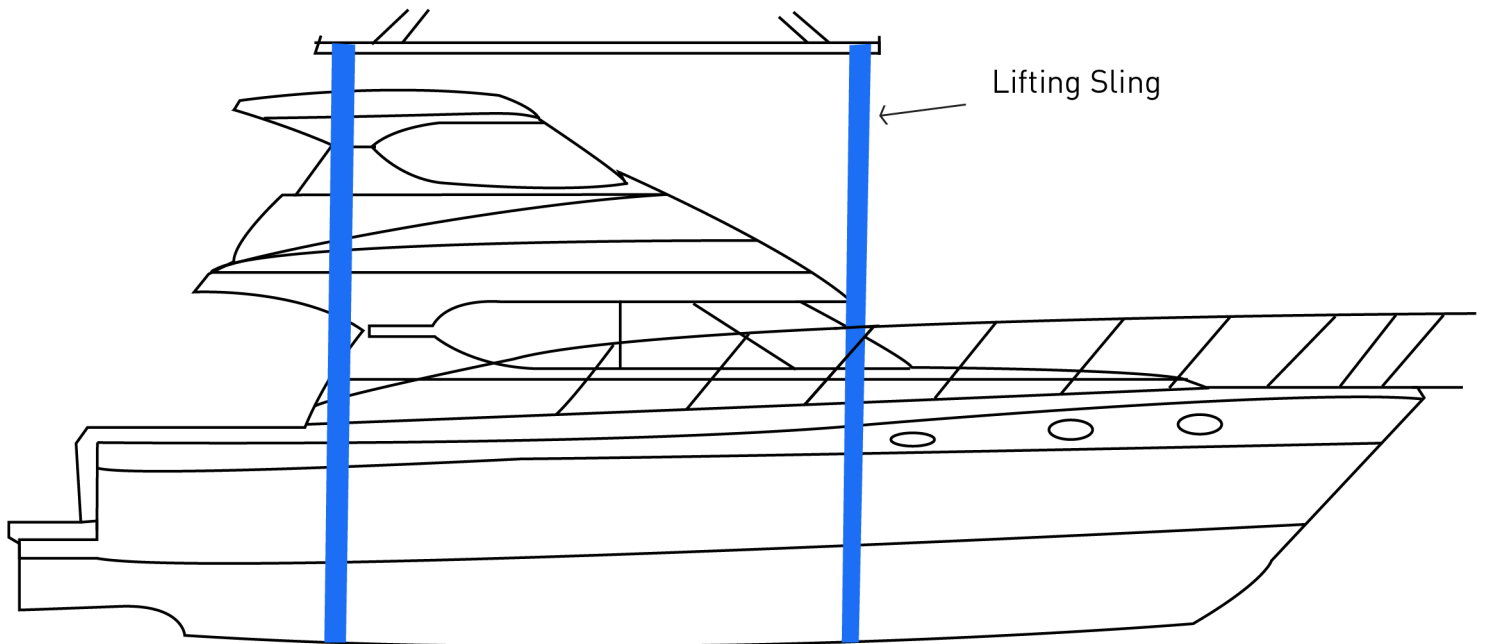

Sling Slippage

Yachts with an increased rise in the keel towards the bow, eg. S&S 34's need to tie the front sling back to a winch. Staff will assist and advise the correct tension. An example is shown below.

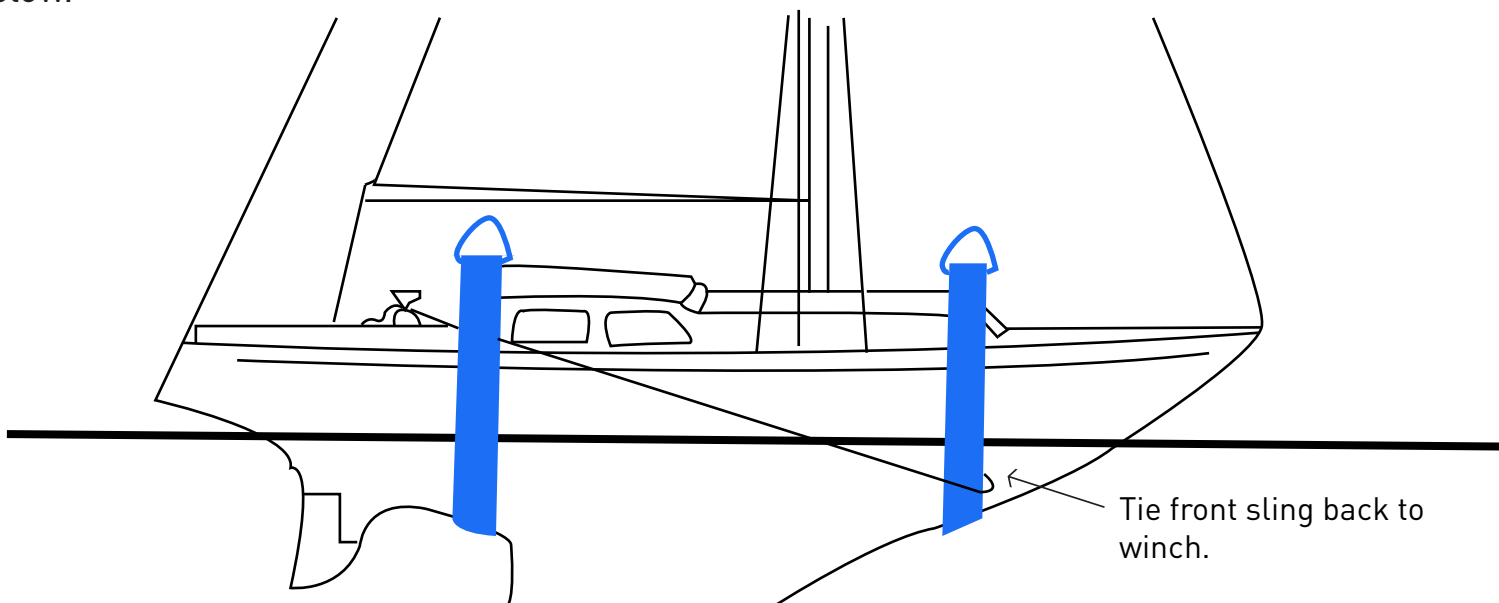

Special Requests

Please advise the Works Staff of any work requirements you are undertaking that may affect the propping of the vessel, e.g., shafts to come out, rudder to come out, engines to be removed, or work to be done on the hull or keel. This information will affect the way the vessel is propped or which cradle is used. Please note further charges may be incurred.

Propping and Cradles

Yachts up to 12 metres go into a small prop cradle which is (supported below the waterline). Yachts above 12 metres go into large prop cradles. Powerboats are supported by steel stands and acrow props. Please advise the staff if the hull is of foam sandwich construction or if the keel is hollow, as this will affect the number of stands required. Aft mounted engines with V-drive gearboxes need extra support under the transom.

Do not remove or adjust props or cradles - ask the staff for assistance.

ENVIRONMENTAL GUIDELINES AND WASTE DISPOSAL

The Fremantle Sailing Club is a member of the national Clean Marinas Australia Program which has a goal to reduce pollution associated with marina facilities, and to promote clean water and clean air. This requires everyone using the Club to put the environment first when considering maintenance on your boat. Ask the staff for assistance for waste disposal.

Bay Clening

We will automatically wash your vessel unless you instruct us not to. Even though the pressure is around 3000psi, it may not remove barnacles or hard coral. Wash fee and environmental levy fees apply.

Alloy Vessels

The cleaning of aluminium vessels with hydrofluoric acid is restricted to Government licensed Acid Cleaning operators. Permission must be sought from the Works Area Manager/Foreman prior to commencement.

Sanding and Grinding

Sanding and grinding may spread dust over a wide area, dry sanding only with commercial vacuum. To avoid costly cleanups of other vessels, do not grind steel on the hardstand. No wet sanding permitted.

All grinding must be in a shed. Remember, you are liable for any damage to other cars and boats, even outside the fence!

Blasting

All blasting is to be done by qualified persons using equipment and materials that conform to the Occupational Safety and Health Regulations 1996 and relevant Australian Standards. All blasting must be carried out in the designated work shed. Blasting on the hard is not permitted. Please contact the works area staff for specialised contractors who meet the Club's environmental and work standards.

Spray Painting

Approval of the Works Area Manager/superior required prior to any spray painting. Full repaint of vessels or any spray painting work is only to be done in the work sheds.

Airless spraying of anti-foul can be done outside but at least three mobile screens must be used. Overspray from painting can travel long distances, even out of the yard, so to avoid having to pay for damage to other vessels and cars, use the spray screens and only paint when the wind conditions are at acceptable levels, i.e. less than 15 km/hr./8 knots. Painting contractors are liable for any damage that occurs to the property of third parties. Waste from airless spray guns shall be confined to contractors own containers and is not to be over-sprayed on bins, vessel cradles, walls, or similar.

Signs are to be clearly displayed when conducting any spray painting operations – signs to read “Caution – Spray Painting In Progress”.



Waste Oil

Waste oil is to be deposited into the waste oil tank located in the Waste Storage Shed next to the Washdown Bay in the Works Area. Oil filters and oily rags must be placed in bins provided. It is illegal to discard waste oil products in rubbish bins. Only empty oil containers may be deposited in the rubbish bins. Please do not leave full containers in waste shed unattended.

Solvents & Paint

Solvents and paint are to be disposed of in the designated waste solvent tank located in the Waste Storage Shed. No waste solvent or paint is to be discarded into waste oil tanks or rubbish bins.

Engine Coolant

Coolant is to be kept separate and placed in the marked drum in The Waste Storage Shed.

Batteries

Discarded batteries are to be placed next to the Waste Storage Shed, not into the bins.

Rubbish & Housekeeping

Owners and tradesmen are responsible for keeping their work bay clean. A bin is provided for each bay and is emptied regularly. Cardboard boxes are to be crushed/flattened. Vessels will not be lifted until the bay is cleaned and charges will apply. The Club does not allow household products, waste or household rubble in the bins. Bays to be left spotless, charges applied if not.

Crane Hire

The 15 ton FRANNA crane is available for hire. Please try and book in advance as it is difficult to program times during the busy season. For mast jobs, a yacht rigger or competent person is required to climb the mast. Contact the Works Office for names of yacht riggers.

Access Steps

The priority for access steps is given to yachts. There are work platforms available but you may need to share or hire your own from suppliers outside the Club. These are to use at your own risk.

SAFETY

The Club is active in promoting and enforcing a safe working environment for Members, Staff and Tradesmen.

Personal Protection Equipment (PPE)

The Works Area is deemed to be a work area by Worksafe Australia, as such Personal Protection Equipment (PPE) is mandatory in the Works Area. Every person in the works area must wear correct PPE, this includes anyone transiting the Works Area (other than in a vehicle). Correct PPE includes;

- High Visibility clothing
- Enclosed foot wear

Additional PPE may be required for additional tasks in the Work Area, if incorrect PPE is not utilised the Works Area staff have the power to stop work until suitable PPE is utilised.

Emergency & Incident Reporting

All incidents (safety and property damage) must be reported to the Works Area staff, if you have any questions on what should be reported see FSC staff for clarification.

The Works Area office has first aid, a defibrillator and oxygen for emergency use, the staff have been trained in First Aid and can assist if required.





FREMANTLE SAILING CLUB

SAFE WORK PRACTICES

You are required to observe the safe work practice requirements of the Work Health and Safety Act 2020, the Work Health and Safety Regulations 2022 and appropriate Australian Standards and Codes of Practice approved by State and Federal Occupational Safety and Health Commissions, as they apply to your tasks. You are required to observe the requirements of the Environment Protection Act 1986 and the regulation as they apply to your tasks.

In particular, if you or your employees are required to use toxic or dangerous chemicals, paints, cleaning agents and abrasive blasting, etc., you are to provide the necessary protective clothing and breathing apparatus and insist on and supervise their use.

You are to ensure that you and your employees are trained and supervised in the safe use of all equipment or tools required to carry out your tasks. You are to ensure that you and your employees observe all safe work practices in relation to working on scaffolding, ladders or planks above ground level, hot works, working at heights and of working in confined spaces.

You are required to insist on, and supervise, the observance of all safe work practices relating to the above requirements.

FREMANTLE SAILING CLUB RULES

You are to ensure that you and all your employees hold a valid access key and vehicle sticker. You are to observe the following Club Rules (not limited too), which impose conditions on members, and by association, on contractors or workers employed by members.

1. All members, tradesperson or person using Club premises, or any property of the Club, or making use of the convenience of facilities provided by the Club, shall be deemed to do so at their own risk.
2. A person shall not whilst on Club premises wilfully obstruct, disturb, interrupt, or annoy any other person in their proper use and enjoyment of the premises.
3. A person shall not disobey or fail to:
Comply with any direction, instruction, request or requirement lawfully given or made by an authorised person in discharge of his/her duty; or
Comply with any notice or signs posted, erected or displayed pursuant to these Rules.
4. A member, tradesperson or person shall be responsible for any loss, damage or expense caused to property of the Club or to that of any other member resulting from non-compliance with any of these Rules.
5. In accordance with Rule 1.2 the Board of Management directs the CEO to apply as follows: No commercial activity shall be conducted on the premises and no boat registered for commercial purposes shall use the Club facilities without the permission of the CEO who shall maintain a record of such approvals.



FREMANTLE SAILING CLUB

p +61 8 9435 8800
w fsc.com.au

151 Marine Terrace, Fremantle WA 6160
PO Box 860, Fremantle WA 6959
ABN 83 047 756 642

6. Dogs are not permitted within the premises except as a guide dog, in association with the Club's security service, services authorised by law (e.g., police & customs) or members' dogs for the purpose of embarkation onto or disembarkation from members' boats. Dogs are not permitted within the clubhouse. They must be on a leash or restrained at all times. Members are responsible for disposing of any dog litter immediately. Dogs may not be left unattended in vehicles or on members' vessels under any circumstance; once a dog is on board the member's boat or returned to the member's vehicle, they must exit Club premises immediately.
7. A person shall not drive a vehicle on the premises in a dangerous or careless manner or without reasonable consideration for other persons or vehicles in the vicinity.
8. A person shall not drive a vehicle at a speed more than 20 kilometres per hour on the premises. Infringement notices will be issued to persons not observing this rule.
9. A person driving a vehicle on the premises shall obey every traffic sign, and every sign, order, or direction addressed to him/her by an authorised person.
10. A person shall not park a vehicle without reasonable consideration for any other persons or vehicle in the vicinity nor in such a manner as to prevent or to impede access to facilities such as waste disposal bins, jetties, ramps, gantries, wheelbarrows etc.
11. All in-water alongside berthing is to be arranged with the Harbour Office apart from Service jetty berthing which can be booked through the Boatyard booking form <https://fsc.com.au/boatyard-booking-form/>
12. A maximum of two vehicles including members vehicle will be permitted to be parked in the service area for each boat being loaded, serviced, or moored in the land-backed pens.
13. Fuelling may be done only at the Fuelling Jetty.
14. No boat may moor at any time at the Fuelling Jetty except for the purpose of fuelling, on completion of which the boat must be removed after adequate ventilation.
15. All waste material from hull cleaning, painting, engine oil change etc. shall be placed in a receptacle provided for that purpose in the service area.
16. Works Area bays are provided to facilitate the servicing, maintenance, and repairs to vessels, and are not to be used for the storage of equipment or vehicles not immediately necessary to affect such servicing, maintenance, or repairs. Bays must be kept free of equipment that presents any OH&S risk, inhibits drainage, prevents access in case of fire, or detracts from the managed order of the area.
17. The removal of anti-fouling or paint must comply with the F.S.C. OHSE Policy.
18. Any works above and beyond the cleaning of vessels in pens, including grinding and other ablative practices are not to be undertaken in pens or on boats on the water.
19. FSC's waste disposal facility is for onsite work-generated waste only.



FREMANTLE SAILING CLUB

p +61 8 9435 8800
w fsc.com.au

151 Marine Terrace, Fremantle WA 6160
PO Box 860, Fremantle WA 6959
ABN 83 047 756 642

APPENDIX : MAP OF FSC WORKS AREA

