



Dinghy Racing Summer Series - Sailing Instructions 2022-23

1. RULES

- 1.1 The rules as defined in The Racing Rules of Sailing (RRS).
- 1.2 The rules as defined in The Racing Rules of Sailing (RRS) Appendix B apply for Windsurfer competitors.
- 1.2 The Australian Sailing Special Regulation Part 2 Off the Beach Boats will apply. [DP]
- 1.3 Arbitration will be conducted in accordance with RRS Appendix T.
- 1.4 RRS 60.1(a) is changed so that '[NP]' denotes a rule that shall not be grounds for a protest by a boat.
- 1.5 RRS 63.1(a), 64.1 and Appendix A5 are amended to enable the Race Committee to apply a standard penalty '[SP]' without a hearing for some breaches of the rules. The SP for this regatta is 2 points.
- 1.6 Notation '[DP]' in a rule means a penalty for a breach of the rule may, at the discretion of the protest committee, be less than disqualification.

2. ADVERTISING

- 2.1 Boats may be required to display advertising chosen and supplied by the organising authority. If this rule is broken, World Sailing Regulation 20.9.2 applies. [DP]

3. ELIGIBILITY AND ENTRY

- 3.1 All participating skippers and crew must be current financial members of Fremantle Sailing Club.
- 3.2 Visiting boats may participate at the discretion of the Organising Authority.
- 3.3 Eligible boats may enter by completing the online entry form via the URL [OTB Summer Series Registration 2022-2023](#)

4. NOTICES TO COMPETITORS

- 4.1 Notices to competitors will be posted on the official notice board located outside the Dinghy Clubhouse.

5. CHANGE TO SAILING INSTRUCTIONS

- 5.1 Any change to the sailing instructions will be posted before 1300 on the day it will take effect, except that any change to the schedule of races will be posted by 1700 on the day before it will take effect.



6 SIGNALS MADE ASHORE

- 6.1 Signals made ashore will be displayed using the flag mast on the west side of the Dinghy Clubhouse lawn.
- 6.2 Boats are not permit launch whilst the 'D Flag' is displayed onshore. [DP]
- 6.3 When flag AP is displayed ashore, '1 minute' is replaced with 'not less than 30 minutes' in the race signal AP.













7 SCHEDULE

- 7.1 The Series Schedule of races shall be as described on the Dinghy Racing Summer Series Calendar included in the Red Book.
- 7.2 Daily Schedule – Afternoon Racing (Consistency and Championship)

Event	Time	Location
Volunteer Briefing	1215 hrs	Dinghy Clubhouse
Competitor Meeting	1230 hrs	Dinghy Clubhouse
First Warning Signal	1330 hrs	
Last Warning Signal	1530 hrs	
Sundowner	After sailing	Dinghy Clubhouse

- 7.3 No warning signal will be made after 1600hrs for Afternoon Racing.
- 7.4 Up to three (3) races shall be completed for any racing session.
The number of races is at the discretion of Race Officer and On water race team on day.

8 CLASS FLAG

Class	Group	Class Flag
Optimist Intermediate	Junior	
Optimist Open	Junior	
Pacer	Junior	
Flying Ant	Junior	
29erXS	Junior	
Windsurfer	Junior	
ILCA 4 / Laser 4.7	Youth	
ILCA 6 / Laser Radial	Youth & Senior	
ILCA 7 / Laser Standard	Senior	
29er	Youth	
505	Senior	
SB20	Senior	
Wind foil	Senior	

9 RACING AREAS



9.1 Racing will be conducted between Success Harbour, South Beach and Fish Rocks.

10 THE COURSES

10.1 The diagrams in Attachment A show the courses, including the approximate angles between legs, the order in which marks are to be passed, and the side on which each mark is to be left.

10.2 At the warning signal for each class, the race committee signal vessel will display on a course board the course to be sailed by each class. The course to be sailed for each class will be displayed beside an image of that classes class flag.

Below is a visual representation of the course board.

	0 1
	0 2

11 MARKS

11.1 Mark descriptions

Marks	Description	Fleet/s
1A	Orange Pimple Buoy	Optimist Intermediate, Optimist Open
1B	Yellow Cylindrical Inflatable Buoy	Laser 4.7, Laser Radial, Laser Standard, Pacer, 29erXS, Windsurfer
1C	Red Cylindrical Inflatable Buoy	29er, 505, Windfoil, SB20
2,5	Yellow Cylindrical Inflatable Buoy	
3S/3P	Orange Pimple Buoy	
4S/4P	Orange Pimple Buoy	



11.2 Dependant on which classes are racing, redundant marks may be omitted. Mark descriptions should take precedent over the relative positions of Attachment A.

12 THE START

12.1 Races will be started in a 3-minute starting sequence as described below, this changes RRS 26.

Minutes before starting signal	Visual Signal	Sound Signal	Meaning
3	Class Flag	One	Warning
2	P,I,U, Black Flag	One	Preparatory
1	Prep Removed	One Long	One Minute
0	Class Flag Removed	One	Starting Signal

12.2 The start line will be between a staff displaying an orange flag on the race committee signal vessel at the starboard end and orange flag on a pin marker on the port end.

12.3 [SP][NP] Boats whose warning signal has not been made shall avoid the starting area during the starting sequence for other races.

12.4 A boat that does not start within 3 minutes after her starting signal will be scored Did Not Start (DNS) without a hearing. This changes RRS A4 and A5.

12.5 The start signal for a class may be the warning signal for a subsequent class.

13 CHANGE OF THE NEXT LEG OF THE COURSE

13.1 To change the next leg of the course, the race committee will move the original mark (or the finishing line) to a new position.

14 THE FINISH

14.1 The finish line will be between a staff displaying an orange flag on the race committee signal vessel at the starboard end and an orange flag on a pin marker at the port end.

14.2 [SP][NP] Except when finishing, boats sailing through a finish line in either direction, while the committee boat is displaying a blue on station flag, will incur a scoring penalty [SP] without a hearing. This changes Rule A3 and A5.

14.3 To assist with timely race management the Race Officer may decide to utilize a finish line on the opposite side of the race committee signal vessel. When the flag "F" is displayed, the finishing line will be between a mast displaying an orange flag on the committee boat at the port end of the line and a buoy an orange flag on a pin marker at the starboard end.



15 PENALTY SYSTEM

15.1 RRS 44.1 is changed so that the Two-Turns Penalty is replaced by the One-Turn Penalty.

16 TIME LIMITS

16.1 Senior & Youth fleet boats failing to finish within 15 mins after the first boat in their fleet sails the course and finishes will be scored Did Not Finish (DNF) without a hearing. This changes RRS 35, A4 and A5.

16.2 Junior fleet boats failing to finish within 15 mins after the first boat in their fleet sails the course and finishes will be scored their current position at the time limit. This changes RRS 35, A4 and A5.

17 PROTEST AND REQUESTS FOR REDRESS

17.1 Protest forms are available in the race office, located in at the Dinghy Clubhouse Office. Protests and requests for redress or reopening shall be delivered there within the appropriate time limit.

17.2 For each racing area, the protest time limit is 60 minutes after the last boat has finished the last race of the day or the race committee signals no more racing today, whichever is later.

17.3 Notices will be posted no later than 30 minutes after the protest time limit to inform competitors of hearings in which they are parties or named as witnesses. Hearings will be held in the protest room, located in the Dinghy Clubhouse Office, beginning at the time posted.

17.4 RRS 60.1(a) is changed so that '[NP]' denotes a rule that shall not be grounds for a protest by a boat.

18 SCORING

18.1 The Dinghy Racing Summer Series consists of two (2) concurrent series, the Consistency Series and Championship Series.

18.2 All Dinghy Racing Summer Series races constitute the Consistency Series.

18.3 Championship Race Days are indicated in the club on-water calendar and the Dinghy Summer Season Poster.

18.4 The Low Point Scoring system RRS A4.1 will apply for both the Consistency Series and Club Championship Series.

18.5 Three races are required to be completed to constitute a series.

18.6 Series definition

18.6.1 When fewer than 5 races have been completed, a boat's series score will be the total of her race scores.

18.6.2 When from 5 to 7 races have been completed, a boat's series score will be the total of her race scores excluding her worst score.

18.6.3 When from 8 to 11 races have been completed, a boat's series score will be the total of her race scores excluding her two worst scores.

18.6.4 When 12 or more races have been completed, a boat's series score will be the total of her race scores excluding her three worst scores.



19 SAFETY REGULATIONS [SP][NP]

- 19.1 Boats shall sign on/off electronically indicating they are On Water via TopYacht 'Sign On' and Sign Off' web page [TopYacht On Water](#)
- 19.2 Boats shall sign off within 60 minutes of completing racing for that session or later at the discretion of the race committee.
- 19.3 Boats failing to sign on or off within prescribed time shall receive a scoring penalty [SP] in the race closest to the indiscretion. No boat will be scored worse than a DSQ.
- 19.4 All Boats registered to race in either series shall confirm they are On Water via TopYacht 'Sign On' and Sign Off' web page [TopYacht On Water](#)
Should a boat having not signed on prior to leaving the shore, the boat 'must' sign on verbally with the Race Committee Start/Finish Boat. It is the responsibility of these boats to ensure they receive acknowledgment from the Race Committee, if the race committee has not acknowledged boats a standard penalty [SP] will apply .
- 19.5 Wind Foil competitors shall wear helmets (that conform to EN 1385 standard) to provide protection to the head and if practical a high visibility rash vest.

20 REPLACEMENT OF CREW OR EQUIPMENT [DP]

- 20.1 Substitution of competitors or damaged or lost equipment will not be allowed without prior written approval of the Organising Authority. Application for a substitution may only be made on the appropriate form, which can be obtained from the Regatta Office. This applies for championship series only.

21 SUPPORT BOATS [DP][NP]

- 21.1 All support boats shall register by contacting the Organising Authority.
- 21.2 All support and coach boats shall keep clear of the racing area while boats are racing (except when rendering assistance to a boat in distress).
- 21.3 Support and coach boats shall remain at least 50 meters outside areas where boats are racing from the time of the preparatory signal until all boats have finished or the Race Committee signals a postponement, general recall or abandonment. All support and coach boats are required to have a VHF Radio and maintain a listening watch on VHF for their racing area (See SI 22.2) or any other channel specified by the Race Committee. When requested by the Race Management Team, support and coach boats shall render immediate assistance as and when required.

22 TRASH DISPOSAL [DP]

- 22.1 Trash may be placed aboard support or official boats.

23 RADIO COMMUNICATIONS

- 23.1 [DP] Except in an emergency, a boat that is racing shall not make voice or data transmissions and shall not receive voice or data communication that is not available to all boats.
- 23.2 VHF radio channels (may be varied at the discretion of the organising authority)

Racing Area	VHF Channel
Dinghy Racing	74



24 PRIZES

24.1 Prizes for Dinghy Racing Summer Series will be awarded at the discretion of the organising authority.

24.2 Dinghy Racing Awards will be awarded as described in Attachment C.

25 DISCLAIMER OF LIABILITY

25.1 Competitors participate in the regatta entirely at their own risk. See RRS 3, Decision to Race. The organising authority will not accept any liability for material damage or personal injury or death sustained in conjunction with or prior to, during, or after the regatta.

26 INSURANCE

26.1 Each participating boat shall be insured with valid third-party liability insurance with a minimum cover of AUD \$10,000,000 per incident or the equivalent.

27 FURTHER INFORMATION

For further information please contact:

Jack Joyner Sailing Coordinator and Training

Email: sailing@fsc.com.au

Telephone: 9435 8809

ATTACHMENT A – DINGHY RACING COURSES

I/O

Trapezoid Windward Finish

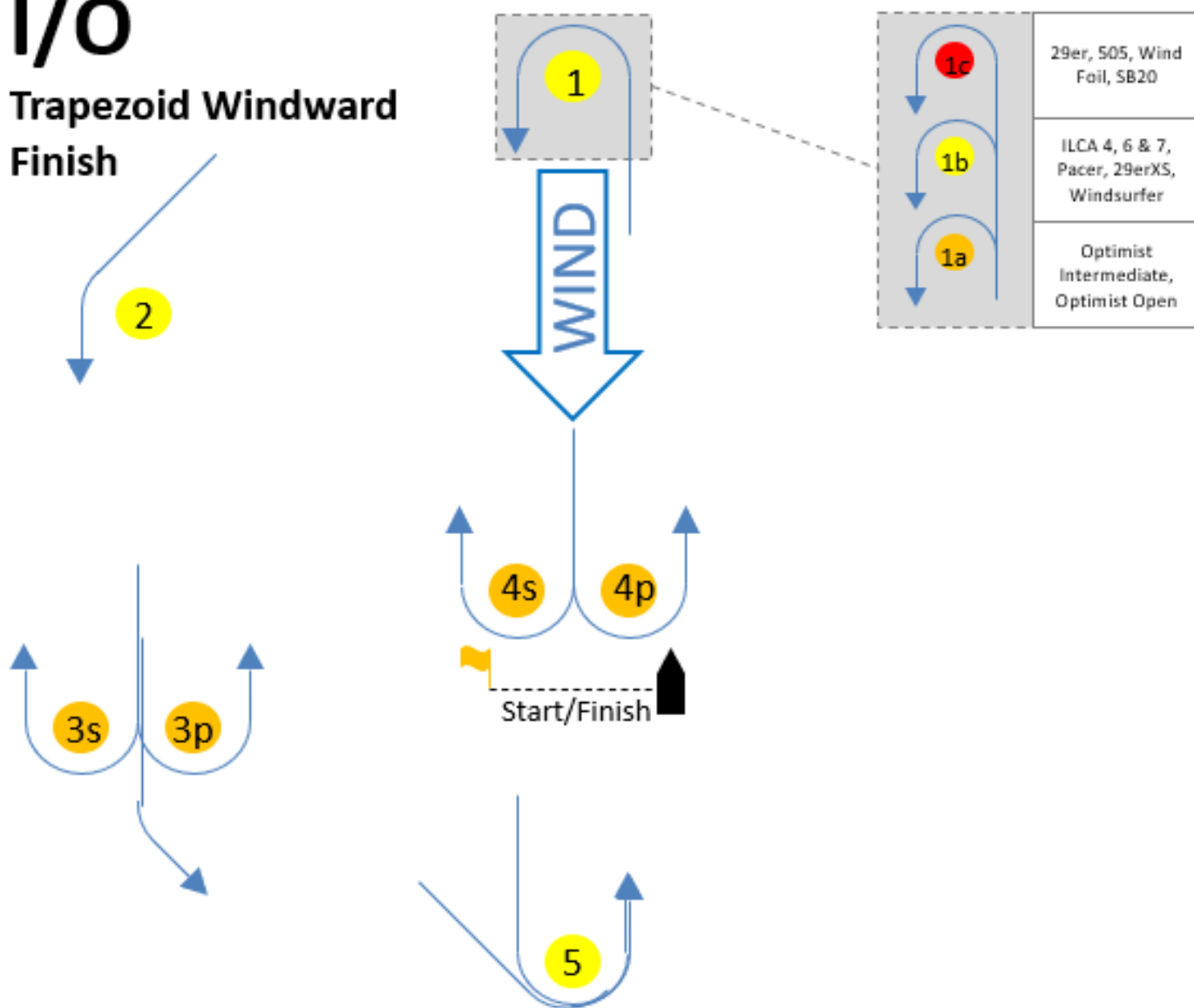

Signal	Mark Rounding Order
I1	Start – 1 – 4s/4p – 1 – 2 – 3p – 5 – Finish
I2	Start – 1 – 4s/4p – 1 – 4s/4p – 1 – 2 – 3p – 5 – Finish
I3	Start – 1 – 4s/4p – 1 – 4s/4p – 1 – 4s/4p – 1 – 2 – 3p – 5 – Finish
O1	Start – 1 – 2 – 3p – 5 – Finish
O2	Start – 1 – 2 – 3s/3p – 2 – 3p – 5 – Finish
O3	Start – 1 – 2 – 3s/3p – 2 – 3s/3p – 2 – 3p – 5 – Finish

ATTACHMENT A – DINGHY RACING COURSES

L Windward Leeward

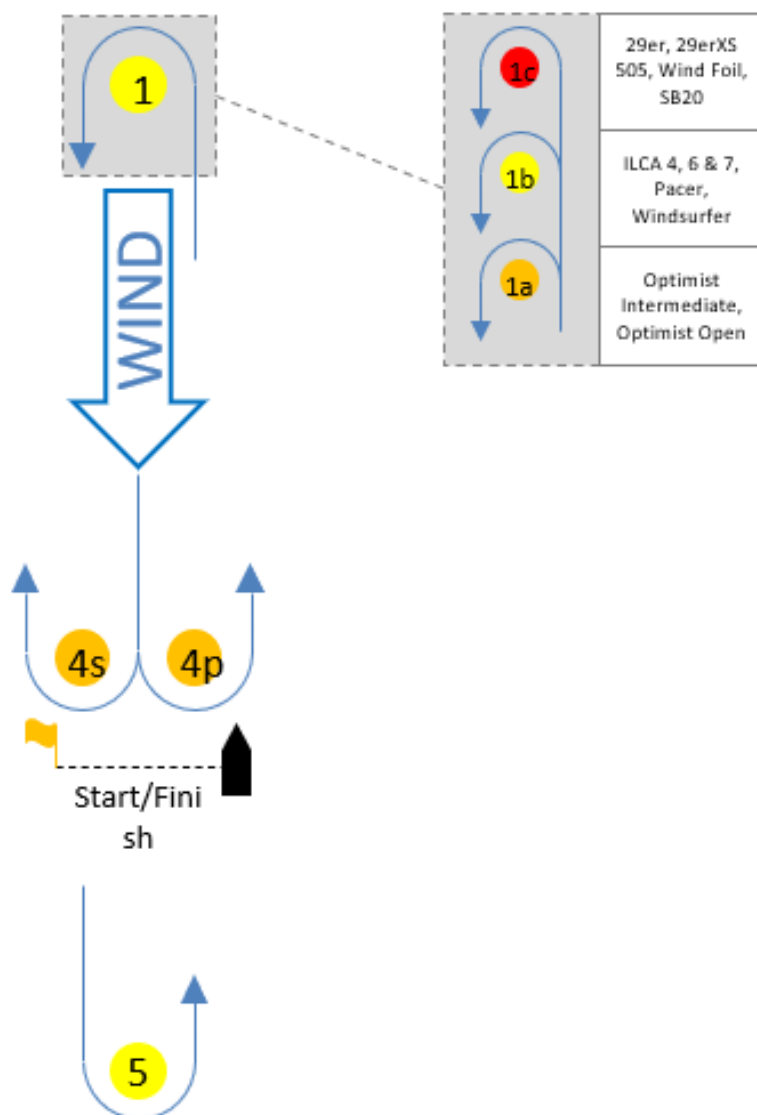

Signal	Mark Rounding Order
L1	Start – 1 – 5 – Finish
L2	Start – 1 – 4s/4p – 1 – 5 – Finish
L3	Start – 1 – 4s/4p – 1 – 4s/4p – 1 – 5 – Finish

ATTACHMENT B – DINGHY RACING AREA

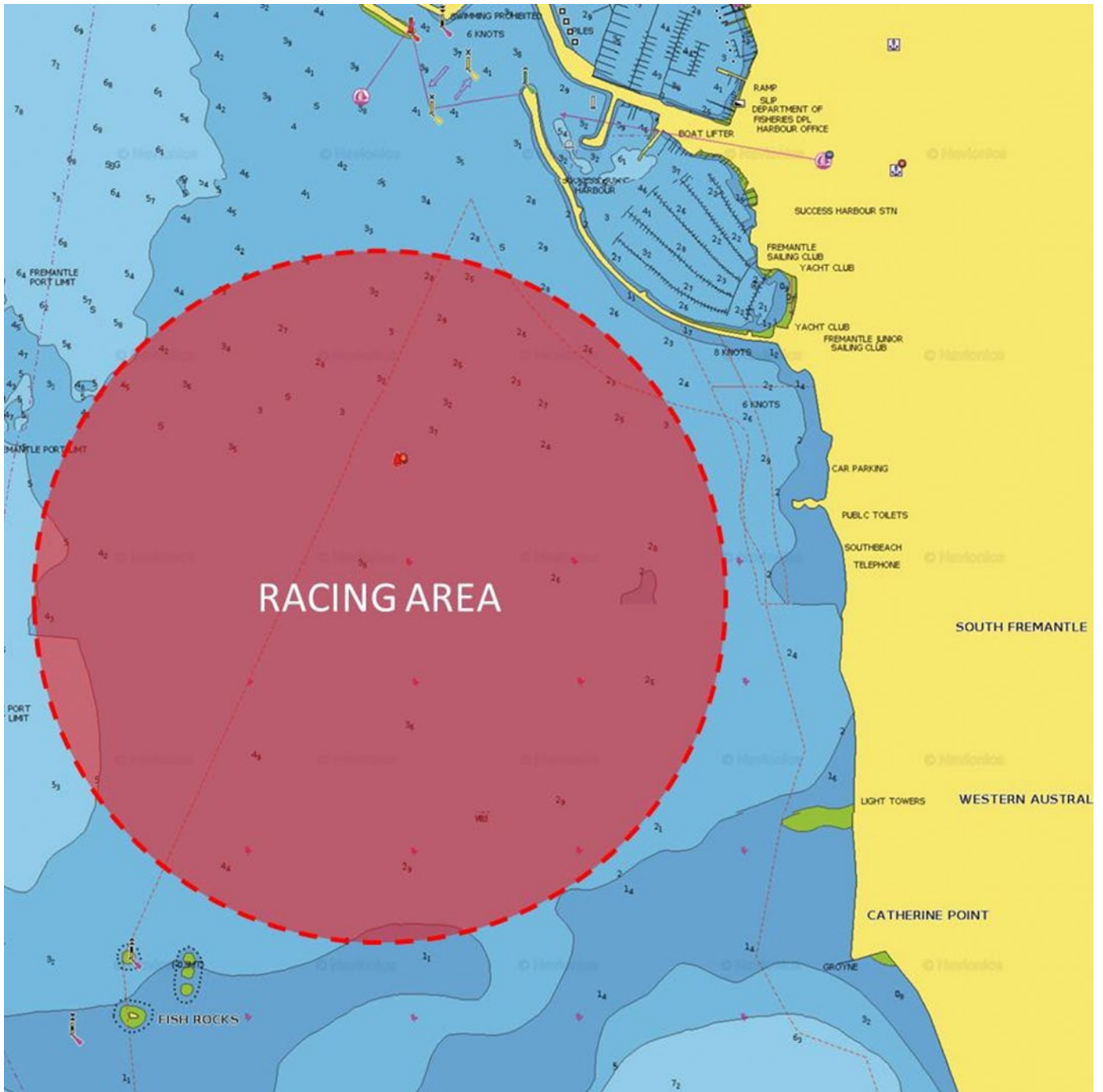



ATTACHMENT C – DINGHY RACING AWARDS

Award	Trophy
Novice Skipper Award	Peter Winter
Most Improved Skipper	Dragon Perpetual Trophy
Most Improved Crew	G&G Hickling Trophy
Junior Sportsmanship Award	Schwepps Trophy
Encouragement Award	Margaret Cook Award
Most Promising	Peter Wainwright Award
Volunteer of the Year	Centenary Trophy
Club Person of the Year	Noel Sweetman
Costa Concordia	Centreboard
Journeyman	Journeyman Cup
Wild West Challenge	Rudder



ATTACHMENT D – TopYacht OnWater Sign On / Off

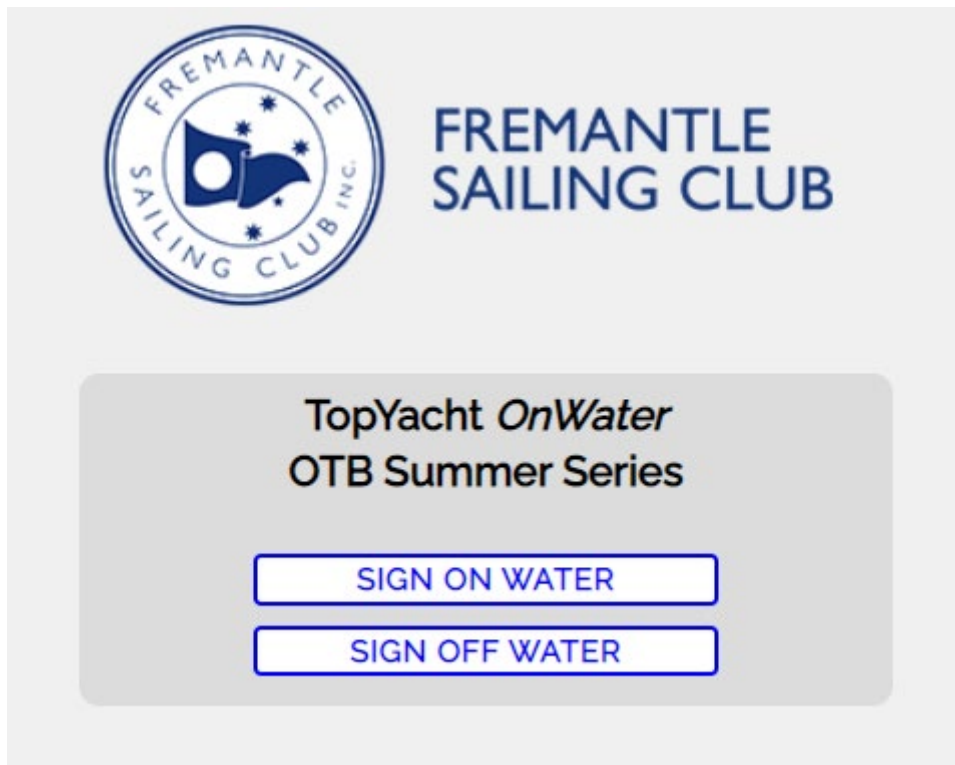

<https://topyacht.com.au/tyow/542>

